

CUMMINS MARINE DUAL STATION PANELS

Panel & Kit No.	Volts	Suit Engine
240.813PC / PW 240.813SC / SW	12v	B220
		B330, B370
		C430, C450

Panel & Kit No.	Volts	Suit Engine
240.814PC / PW 240.814SC / SW	24v	B220
		B330, B370
		C430, C450

MAIN PANEL – Layout



240.813PW MASTER PANEL



240.813SW MASTER PANEL

MAIN PANEL – Bill of Materials

Qty	12 Volt P/no.	24 Volt P/no.	Description
2	-	240.051	Globe 24v Tacho illumination
1	170.12V3	170.24V3	Electronic warning device
1	170.713	170.713	Button Start - push on
1	240.021	240.022	Buzzer behind panel mount
1	411.095	411.095	Tacho Amplifier
2	43789	43789	Double-side Tape
1	500.713	500.713	Universal Panel Loom – rev 2
1	850.009	850.009	Ignition Switch (With Key)
1	850.012	850.012	Panel – Starboard Woodgrain (240.813/4 SW only)
1	850.013	850.013	Panel – Starboard Carbon Fibre (240.813/4 SC only)
1	850.017	850.017	Panel – Port Carbon Fibre (240.813/4 PC only)
1	850.018	850.018	Panel – Port Woodgrain (240.813/4 PW only)
4	850.041	850.041	Bezel chrome 52mm Ocean Line
1	N02 012 110 CL	N02 012 110 CL	Tacho-Hourmeter
1	N02 124 110	N02 124 510	Oil Pressure Gauge
1	N02 124 114	N02 124 514	Gear Box Pressure Gauge
1	N02 321 602	N02 321 702	Water Temp Gauge
1	N02 410 802	N02 410 902	Voltmeter
3	N05 800 762	N05 800 764	Warning Light w/globe – gauge mount

SECONDARY PANEL – Layout



240.813PW AUXILLIARY PANEL



240.813SW AUXILLIARY PANEL

SECONDARY PANEL – Bill of Materials

Qty	12 Volt P/no.	24 Volt P/no.	Description
2	-	240.051	Globe 24v Tacho illumination
1	170.12V3	170.24V3	Electronic warning device
1	170.713	170.713	Button Start - push on
1	170.714	170.714	Button Stop – push off
1	240.021	240.022	Buzzer behind panel mount
1	411.095	411.095	Tacho Amplifier
2	43789	43789	Double-side Tape
1	500.713	500.713	Universal Panel Loom – rev 2
1	850.012	850.012	Panel – Starboard Woodgrain (240.813/4 SW only)
1	850.013	850.013	Panel – Starboard Carbon Fibre (240.813/4 SC only)
1	850.017	850.017	Panel – Port Carbon Fibre (240.813/4 PC only)
1	850.018	850.018	Panel – Port Woodgrain (240.813/4 PW only)
4	850.041	850.041	Bezel chrome 52mm Ocean Line
1	N02 012 110 CL	N02 012 110 CL	Tacho-Hourmeter
1	N02 124 110	N02 124 510	Oil Pressure Gauge
1	N02 124 114	N02 124 514	Gear Box Pressure Gauge
1	N02 321 602	N02 321 702	Water Temp Gauge
1	N02 410 802	N02 410 902	Voltmeter
3	N05 800 762	N05 800 764	Warning Light w/globe – gauge mount

WIRING LOOMS - Bill of Materials

NOTE: Following list notes the **ONLY** differences between various engine models.

Qty	P/no. 12 & 24 vdc	Used on	Description
1	500.703	All 12 & 24v	10 meters Extension Loom
1	500.704	All 12 & 24v	6 meters Extension Loom
1	500.705	All 12 & 24v	“Y” Extension Loom
1	500.716	All 12 & 24v	Adaptor Loom (from VDO plug to Cummins plug)

Optional Extras

1	500.709	All 12 & 24v	Engine Loom Universal
1	500.712	All 12 & 24v	Fuel Solenoid Extension, B220 engine 12, 24v
1	500.714	All 12 & 24v	Alternator Extension Universal, “L” plug, B220, B330, B370, C430, C450 engine 12, 24v

SENDER KIT - Bill of Materials

Qty	P/no.12 & 24 vdc	Used on	Description
1	320.058	All	1/2"-14 NPTF 5/8"-18 UNF 25mm Temp Sender Adaptor
1	325805003002C	All 320.710	5/8"-18 UNF 40-120°C Water Temp Sender...Dual stn
1	362081001002K	All 360.711	1/8"-27 NPTF 0-10 Bar Oil Pressure Sender...Dual stn
1	362081002001K	All 360.712	1/8"-27 NPTF 0-25 Bar Gear Box Pressure...Dual stn

WIRING – Panel Layout

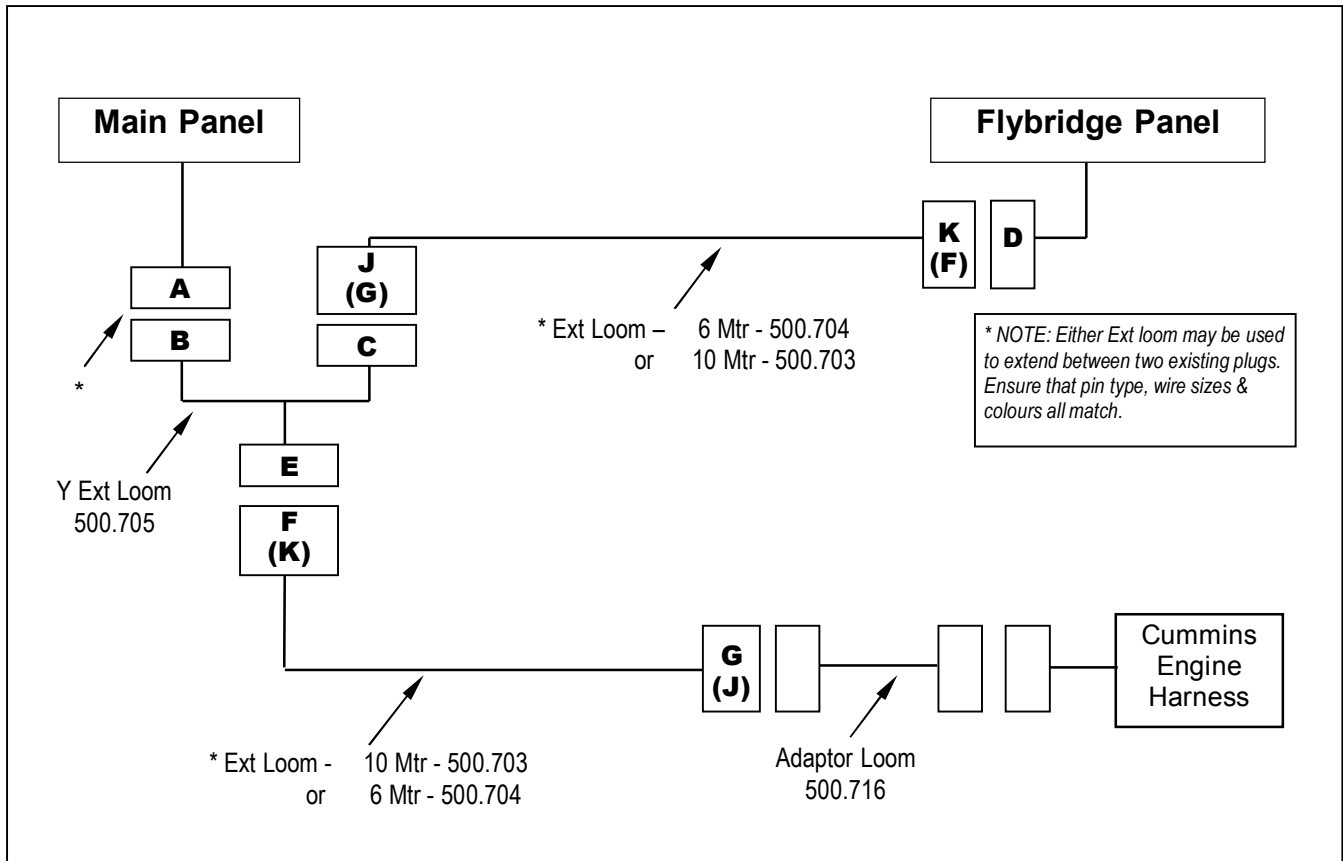

WIRING – Colour Codes

	Male housing / female terminals		Connection
	Plug A - Main Panel Plug	A	Red 6mm
Plug D - Secondary Panel Plug	B	Black 6mm	Ground / Earth -
Plug E - Y Ext Plug	C	Yellow 3mm	Spare
Plug G - 10 Mtr Ext.	D	White 3mm	Gear Box Oil Press Sender
Plug J - 6 Mtr Ext.	E	Green 3mm	Tacho signal from mag. pick up
	F	Red 3mm	Spare
	Female housing / male terminals		Connection
	A	Purple 4mm	Run Solenoid
	B	Brown 3mm	Engine Temperature Sender
	C	Blue 3mm	Oil Pressure Sender
	D	Orange 3mm	Starter Solenoid
	E	Grey 3mm	Spare
	F	Red/White 3mm	Spare

Note: All matching sockets to the above will have mirror image connections.

ALARM SWITCH P/No. 170.12V3 / 170.24V3

DESCRIPTION

The multifunction alarm switch on these panels is designed to turn on a warning light for falling engine or gearbox oil pressures and rising engine coolant temperature. The panel is also wired to give an audible alarm on low engine oil pressure or high engine coolant temperature. All panels are preset at the factory as follows...

Low engine oil pressure	0.5 bar	= 22 Ω single stn	= 11 Ω dual stn
Low gearbox oil pressure	19 bar	= 145 Ω single stn	= 73 Ω dual stn
High engine coolant temp	96°C	= 43 Ω single stn	= 22 Ω dual stn

A 20-turn potentiometer is fitted, allowing fine adjustment, if ever necessary, across the appropriate scale of the gauge. Clockwise will raise the set point & anti clockwise will lower it.

CALIBRATION

Connect the sender terminal to a variable resistance matching your gauge and set the gauge to read in its normal area. Adjust the variable resistance so the gauge reads at the alarm point you desire.

Turn the pot clockwise or anticlockwise until the contact just closes and the light & buzzer come on. Test your setting by adjusting the variable resistance up and down and do any fine-tuning on the potentiometer.

WIRING DIAGRAM

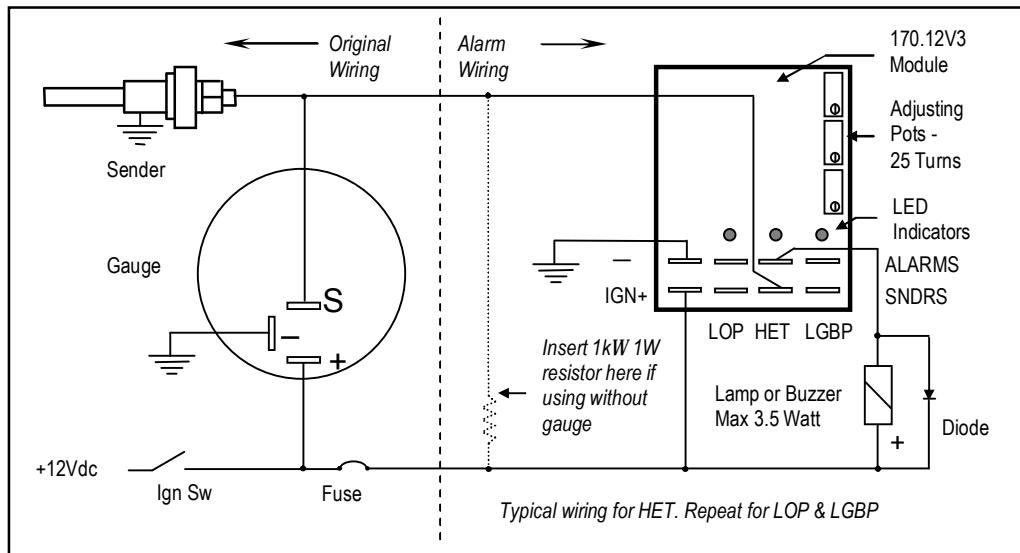

TACHOURMETER SETTING

This tachourmeter is set up to run from the Cummins OEM magnetic pick up. Default setting is for a ring gear with 159 teeth. If this needs to be altered for any reason, follow the procedure below.

1. Determine the number of teeth on your ring gear. Calculate the pulse setting for your engine with the formula... $P = N/16$, where P = Pulse setting and N = No. of ring gear teeth.
For example, if $N = 160$, then $P = N/16 = 10.00$
2. Locate the tacho adjust button at the bottom of its access hole, lower rear of the tacho case. Using a small pin punch or screwdriver, push and hold down this button. Then turn the ignition key switch on. The display will show "PULSE" and "ADJUST" alternating every 2 seconds. Release the key when "PULSE" is displayed.
3. When the function "PULSE" is selected, a reading similar to "P 9.94" appears on the display after approx 3 seconds. The last digit in the display flashes. Begin entry by pushing the button to scroll through digits 0 – 9. After the correct digit is selected, wait approx 4 seconds for this to be accepted and the next digit on the left to begin flashing.
4. Stop pushing the button once the correct setting has been obtained. Wait approx 10 seconds for the tacho to accept the final reading. The display then changes over to operating hours. The setting procedure is now completed. The setting may be checked by repeating step two and reading the "PULSE" function.
5. **NOTE: Do not turn the key off until the final setting has been accepted. This is indicated by the display returning to the operating hours function.**

CUMMINS Marine - Dual Station - Master Panel

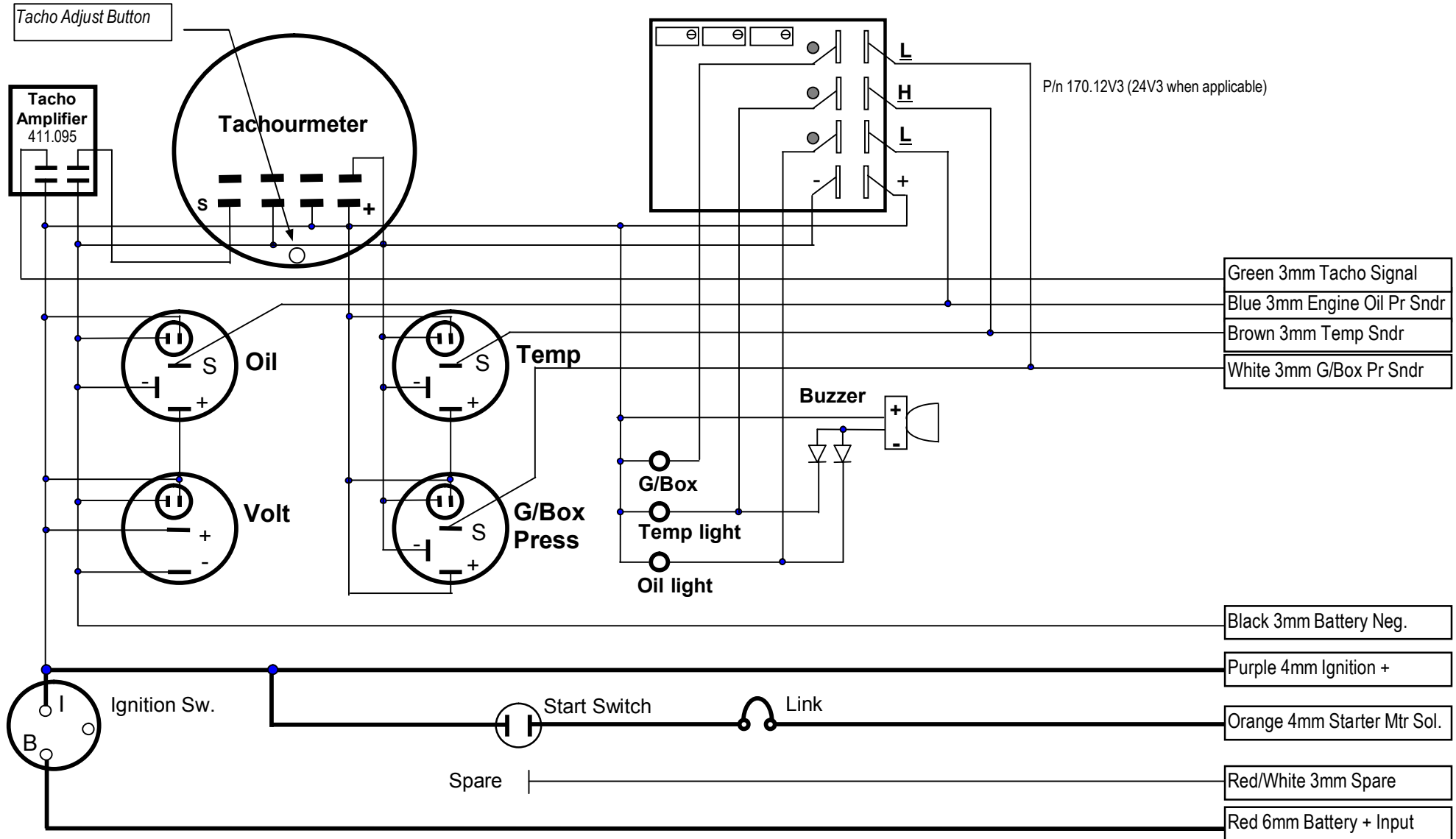

CUMMINS Marine - Dual Station - Auxiliary Panel

