

ADJUSTABLE TIMER MODULE – 12/24VDC

P/No. DCS 973D - Connection Instructions for 12/24V Module

GENERAL

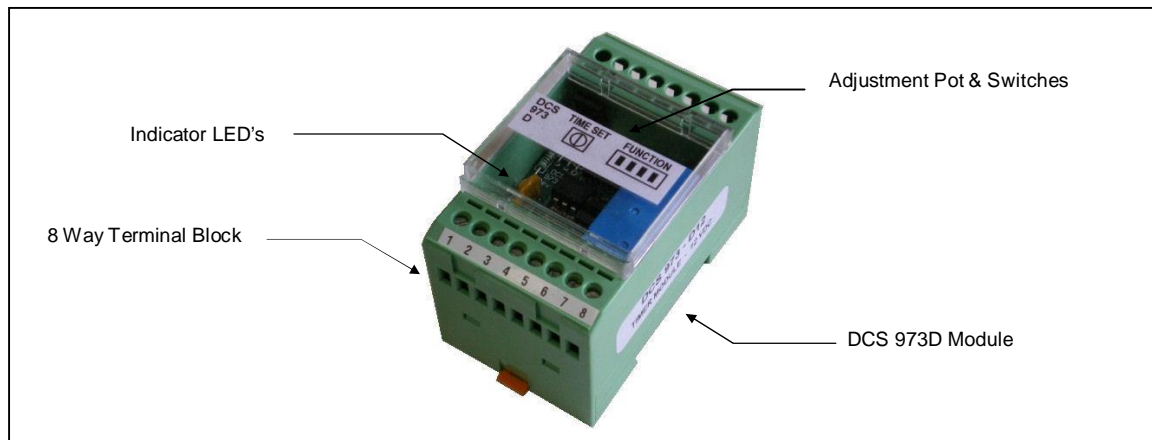

The DCS 973D Timer Modules are designed as general purpose multifunction timers and for DC supply applications where fluctuation of supply can be very high, e.g. whilst starting a diesel engine. It provides 8 functions and 4 time ranges. One volt free contact output and one N/O or N/C, +Ve or -Ve output at 5 Amp, selectable by programming links A and B.

The settings of the different functions and timing ranges are performed with the help of a selector switch. The unit is enclosed in a robust DIN rail plastic housing with LED indication for supply *on* and relay *operation*. Settings and programming links are accessible by unclipping the clear front cover. The printed circuit board and components are tropic proofed.

NOTE: This module is designed as a universal unit to suit as many automotive type applications as possible. However there may be some systems where the input or output signals are not compatible with this unit. The manufacturer is not responsible for incorrect fitting or damage caused by or during the fitting of this module.

OPERATION AND FUNCTIONS

1. DELAY ON AFTER POWER UP

On application of a continuous supply voltage to terminals 1 and 3, the timing period begins. The relay LED will illuminate and outputs change over when the set time period has elapsed. The unit is reset by removing the supply voltage.

With continuous supply voltage connected to terminal 1 and 3, by applying +Ve via an external contact to terminal 4 the timer will be reset. Timing will start again when +Ve is removed from terminal 4.

2. INSTANT ON WITH DELAY OFF AFTER POWER UP

On application of a continuous supply voltage to terminal 1 and 3 the relay LED will illuminate, the outputs will change over and the timing period begins. When the set time period has elapsed, the relay LED is extinguished and outputs will change back to normal state.

With continuous supply voltage connected to terminals 1 and 3, and the initial timing period elapsed, the relay LED will be extinguished. By applying +Ve via an external contact to terminal 4, the relay LED will illuminate and the outputs will change over. The removal of +Ve from terminal 4 will start the time delay. When the set time period has elapsed, the relay LED is extinguished and outputs will change back to normal state.

3. CYCLE TIMING DELAY ON ENERGISE

On application of a continuous supply voltage to terminal 1 and 3, timing starts and after the set time period the relay LED will illuminate and the outputs will change state. The unit will cycle with equal time on/off time periods until supply is removed.

By applying +Ve to terminal 4 the unit will reset and cycling is inhibited until +Ve is removed.

4. CYCLE TIMING INSTANT ON

On application of a continuous supply voltage to terminal 1 and 3 the relay LED will illuminate and the outputs change over and the timing starts. After the set time period the relay LED will extinguish and outputs change state. The unit will cycle with equal on/off time periods until supply is removed.

By applying +Ve to terminal 4 the unit will reset and cycling is inhibited until +Ve is removed.

WIRING DIAGRAM

TIME RANGE SELECTION

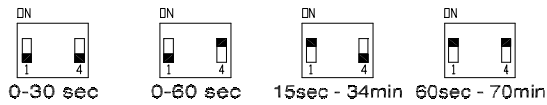

FUNCTION SELECTION

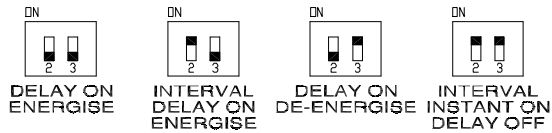

VE+OR VE-NOORNC 1AMP OUTPUT SELECTION

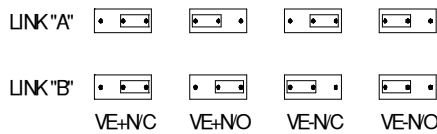

CONNECTIONS

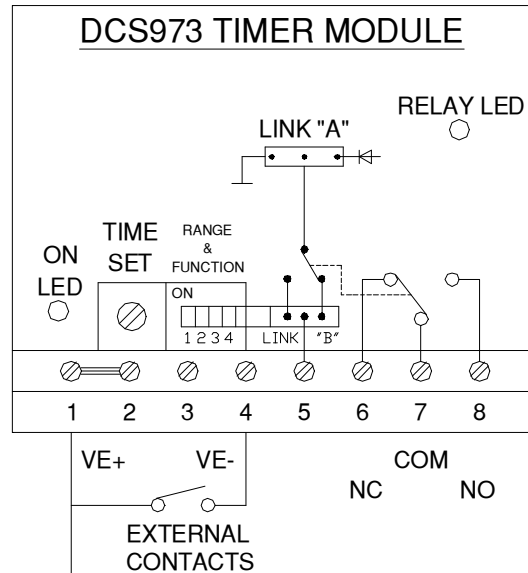

ALTERNATE SELECTION CHART

DIP SWITCH NO \Rightarrow	1	2	3	4
Switch Posn. - ON	Minutes	Cycling	Instant On Delay Off	0 - 60
Switch Posn. - OFF	Seconds	One Shot	Delay On	0 - 30

TIPS

Temporarily replacing your alarm circuit with a test light can simplify the setting procedure.
When switching relay and solenoid coils with other electronic items, it is recommended to fit reverse EMF diodes across all coils.
This unit will not work if supply to it fails or the external switching fails.
It is good practice to make all circuits fail safe where possible and practical.

SPECIFICATIONS

- Dimensions: 75mm x 45mm x 53mm (58mm mounted on DIN rail).
- Voltage, Current: 12V (8-16.5VDC), 24V (16-33VDC) Neg Gnd. 10mA Quiescent, 12V.
- Protection: Protected for reverse polarity.
- Output Rating: 12/24VDC 5Amp, Resistive
- Case Material: Thermoplastic
- Operating Temperature: -10°C to +60°C
- Relay Contacts: One voltage free SPDT, One NO or NC, +Ve or -Ve switching, Selectable by programming links A and B.